

As in previous lessons, the first protrusion will be sketched on **FRONT**. Use Figure 4.4 for the protrusion dimensions. Use only the **5.50**, **R1.00**, **1.125**, and **25°** dimensions.

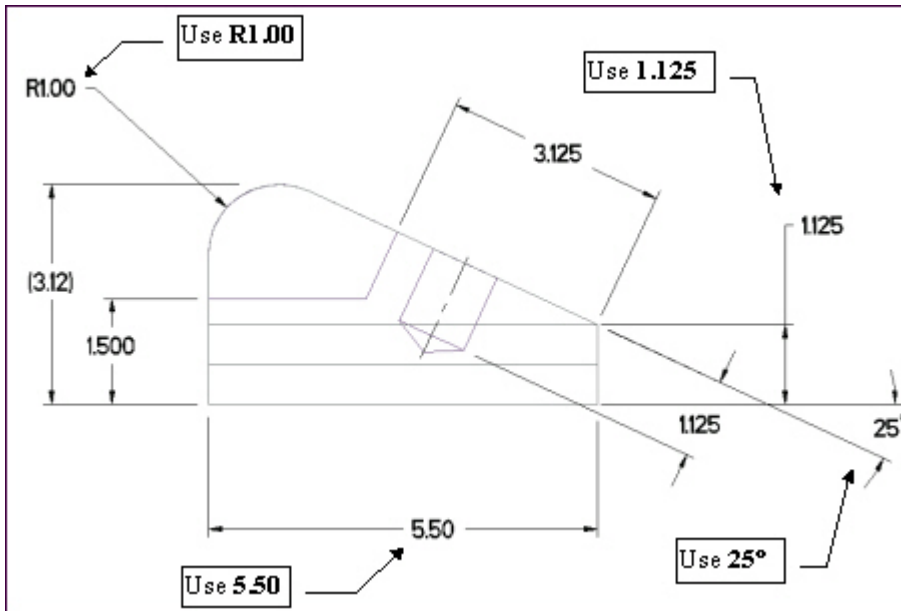

Figure 4.4 Anchor Drawing Front View

Create the first protrusion, click: ⇒ **Extrude Tool** ⇒ **Placement** ⇒ **Define** [Fig. 4.5(a)] ⇒ Sketch Plane--- Plane: select **FRONT** datum ⇒ **Sketch** from Sketch dialog box ⇒ **Tools** ⇒ **Environment** ⇒ **Snap to Grid** ⇒ **OK** ⇒ **Toggle the grid on** ⇒ **RMB** anywhere in the graphics window ⇒ **Line** [Fig. 4.5(b)]

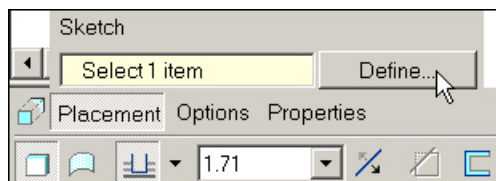

Figure 4.5(a) Dashboard

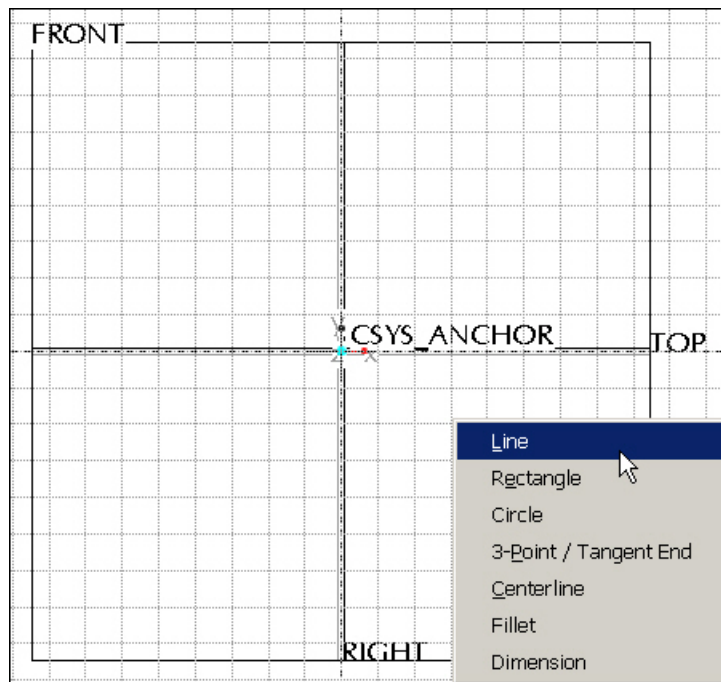

Figure 4.5(b) Selecting the Line Tool with the Pop-up Menu